

Serie B.651

B.651Bremse
brake**B.651.R**Bremse mit Radiator
brake with radiator**B.651.V**Bremse mit Lüfter
brake with fan**C.651**Kupplung
clutch

Max. Drehmoment / Max. torque	65 Nm
Restdrehmoment / Residual torque	0,4 Nm
Max. Stromaufnahme / Max. current	1 A
Widerstand bei 20 °C / Resistance at 20 °C	24 Ohm
Spannung / Supply Voltage	24 V (PWM)
Wärmeableitung / Power dissipation	170 W
Wärmeableitung mit Radiator / Power dissipation with radiator	400 W
Wärmeableitung mit Lüfter / Power dissipation with fan	800 W
Wärmeableitung der Kupplung bei 500 U/min. / Power dissipation of the clutch at 500 RPM	280 W
mit Radiator bei 500 U/min. / with radiator at 500 RPM	950 W
Wärmeableitung der Kupplung bei 1000 U/min. / Power dissipation of the clutch at 1000 RPM	350 W
mit Radiator bei 1000 U/min. / with radiator at 1000 RPM	1200 W
U/min. min.-max. / RPM min-max	40-2000
Max. Arbeitstemperatur / Max. working temperature	70 °C
Gewicht kg / Weight kg	6,5 [B.651] / 9 [B.651.R] / 8,8 [B.651.V] 9,4 [C.651] / 9,4 [C.651.R]

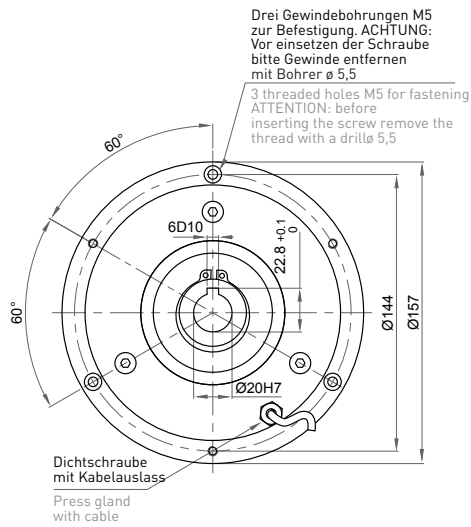
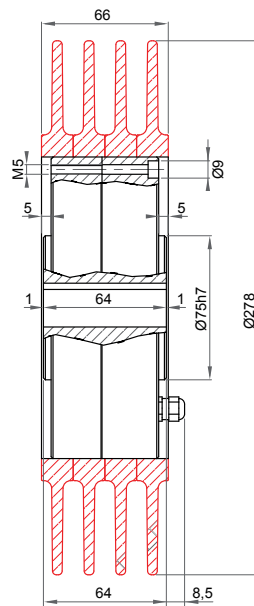
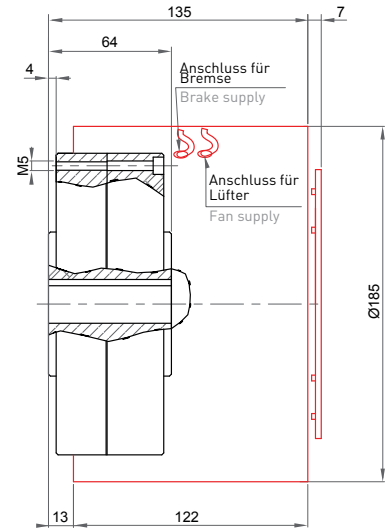
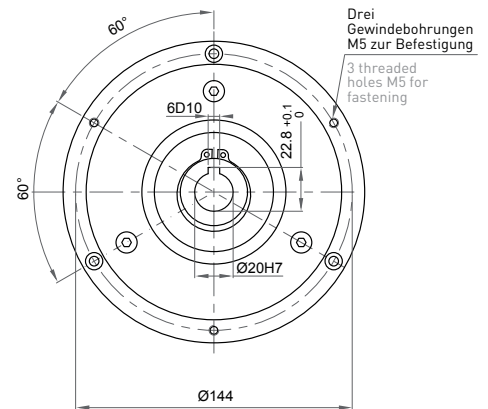
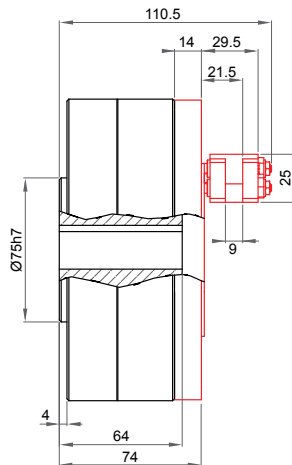
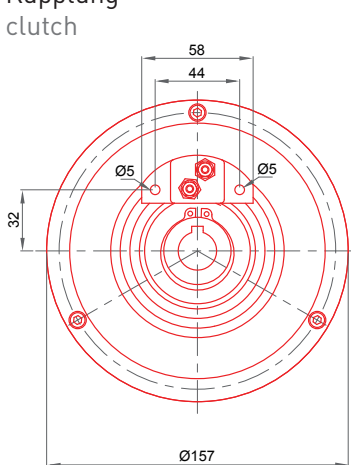