

## Serie B.5000

**B.5000**Bremse  
brake**B.5000.R**Bremse mit Radiator  
brake with radiator**B.5000.V**Bremse mit Lüfter  
brake with fan**C.5000**Kupplung  
clutch

Max. Drehmoment / Max. torque	500 Nm
Restdrehmoment / Residual torque	6 Nm
Max. Stromaufnahme / Max. current	0,94 A
Widerstand / Resistance	25,5 Ohm
Spannung / Supply Voltage	24 V (PWM)
Wärmeableitung / Power dissipation	1300 W
Wärmeableitung mit Radiator / Power dissipation with radiator	2500 W
Wärmeableitung mit Lüfter / Power dissipation with fan	4000 W
Wärmeableitung der Kupplung bei 500 U/min. / Power dissipation of the clutch at 500 RPM	2800 W
mit Radiator bei 500 U/min. / with radiator at 500 RPM	4000 W
Wärmeableitung der Kupplung bei 1000 U/min. / Power dissipation of the clutch at 1000 RPM	3500 W
mit Radiator bei 1000 U/min. / with radiator at 1000 RPM	5000 W
U/min. min.-max. / RPM min-max	40-1500
Max. Arbeitstemperatur / Max. working temperature	70 °C
Gewicht kg / Weight kg	59 [B.5000] / 62 [B.5000.R] / 62 [B.5000.V] 62 [C.5000] / 65 [C.5000.R]

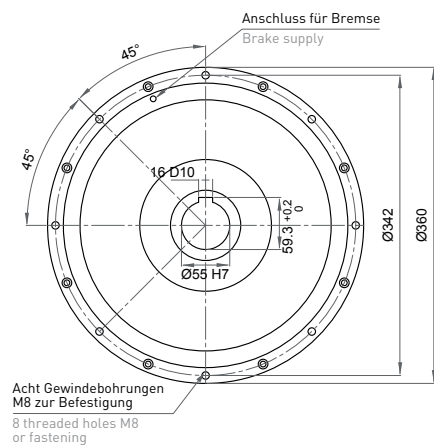
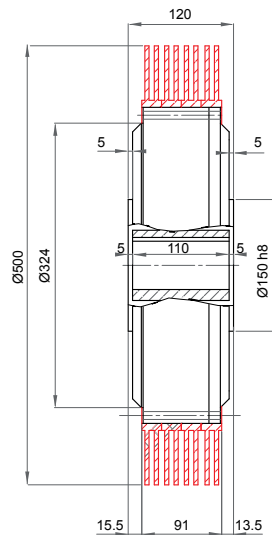
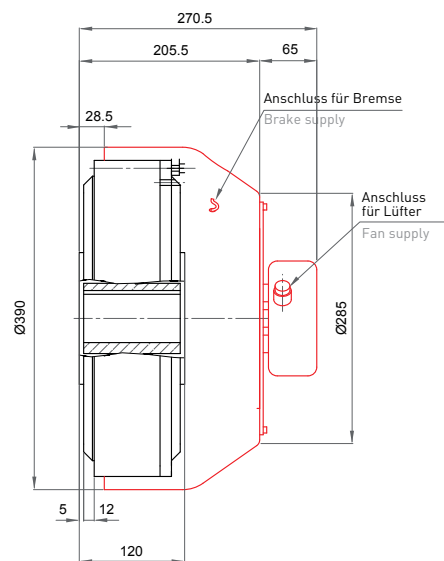
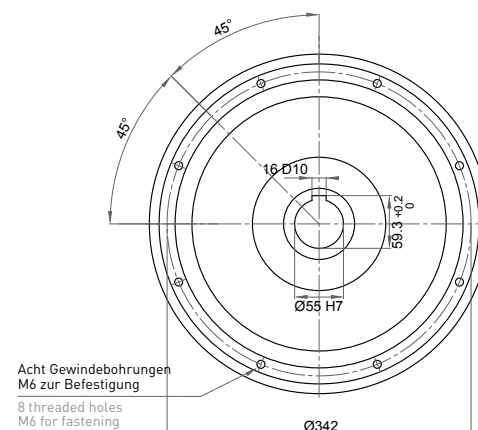
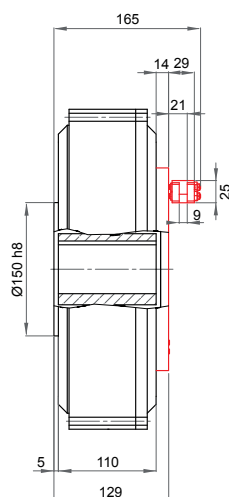
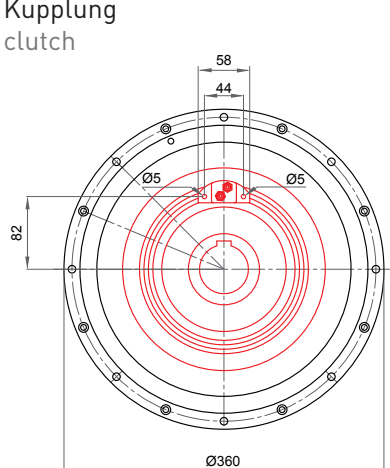